

OWNER'S MANUAL

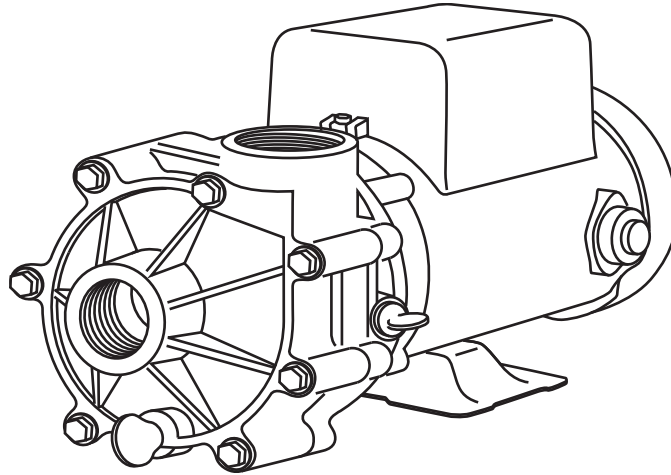

Cascade
HIGH RPM PUMPS



PUMP MODEL: _____

SERIAL #: _____

DATE PURCHASED: _____

RETAIN THIS INFORMATION FOR FUTURE REFERENCE.

FOR QUESTIONS REGARDING INSTALLATION, OPERATION
OR MAINTENANCE CALL (503) 356-5888

PerformancePro



PROUDLY BUILT IN THE USA SINCE 2000 **PUMPS**

Important Safety Instructions

Please read all instructions completely before installing or operating the pump.

Save this manual for future reference regarding installation, operation, maintenance and troubleshooting of this pump.

Please note the safety warning symbols as noted below:

	This warning symbol indicates the potential for personal injury or damage to the pump! Please be cautious!
	This symbol indicates a hazard which if not avoided could result in serious personal injury or death! Please be cautious!

Please carefully read and follow all safety instructions and procedures listed on the pump and in this manual.

 **WARNING**

Pressure Hazard!

Do not run your pump with discharge ports closed or blocked. Be sure to release system pressure before working on the pump.



 **WARNING**

Electrical Hazard!

Ground pump before connecting to power supply! Risk of shock, burn or death if not handled properly.



 **WARNING**

Burn Hazard!

Operating motor can be very hot. Do not touch motor while running. Allow to cool 30 minutes after shut down before handling. Risk of burn.



GENERAL WARNINGS

1. This pump and motor unit should be installed by a qualified electrician or service person in accordance with all applicable state and local codes and ordinances, and in accordance with the National Electrical Code. Improper installation may create a mechanical or electrical hazard which could cause damage to property and could result in serious injury or death. 
2. In order to avoid serious injury or death, always disconnect power to the motor before servicing the pump and follow all instructions in this manual.
3. Always use the schematic on the motor for all electrical connections.
4. Never run the pump dry. The Cascade is not self priming and is best suited for flooded suction systems. The pump housing and entire suction line must be filled with water for proper operation prior to starting the pump. Running dry will void the warranty and can result in permanent damage to the pump unit.
5. To prevent incorrect motor rotation, install a ball or swing type check valve. Do not use spring check valves.
6. Maintain a minimum flow rate of at least two gallons per minute to avoid damage to the pump unit.
7. Visually inspect the pump and motor a minimum of once per week. If any leakage between the motor and pump housing is present, replace the mechanical seal. The seal faces wear similar to car tires and must be replaced periodically. For critical applications, replace the mechanical seal yearly. If pump is excessively noisy, shut it down and contact support.
8. For 3 phase motors, ensure proper rotation. See section 7 in electrical for details.
9. In freezing environments it is advisable to winterize your pump to prevent damage. Do not allow pump or system plumbing to freeze, as freezing can cause damage that may lead to equipment failure or possible injury and will void the warranty.

Understanding priming and pump operation

The Basics

Your pump is powered by an electric motor that directly affects your water flow rate. When the electric motor is turned on it utilizes centrifugal force to generate velocity of the water. The water then flows into the optional strainer pot if installed to filter out debris or if not, will flow directly into the pump housing. Water continues its flow into the eye of the impeller where the water meets the impeller vanes and converts kinetic energy into static pressure allowing the pump to maintain pressure and is then forced out of the pumps discharge port resulting in continuous water flow for your waterscape oasis.

The Prime

The Cascade High RPM pump is not a self-priming pump which makes it best suited for flooded suction systems. This means that it is designed to best operate below the water source surface level. Because the Cascade is not self priming it is recommended to install a rubber flapper type swing check valve and a priming pot to assist in priming unless it is on a gravity fed system. It is important to note that operating above the water source surface level may negatively affect the pumps overall performance. After filling the pump housing, intake pipe and priming pot (if present) with water and starting the pump, if there is no water in the intake pipe between the swing check valve and the water source, a reduced flow may be noticed for a minute. This is normal and will increase to full performance within a few minutes as long there are no obstructions or air leaks. If after a few minutes, full flow is not achieved, shut the pump off and check connections.

Never use a spring loaded check valve as it will reduce or stop flow.

With Valve

What to expect for priming cycle **with** swing check valve installed. Essentially, when utilizing a properly installed swing check valve the priming process is less time consuming and is more efficient. An optional priming pot is also helpful. When installing a swing check valve, be sure your connections are properly seated and are airtight. The valve should be as low and as close to your source water as possible to maintain constant pressure. The best installation location for a check valve is underwater when possible, as this can provide an air tight fit even without PVC adhesive. Some swing check valves have true union connection fittings that offer easier access for cleaning when needed. The pump housing, intake pipe and strainer pot (if present) are then filled with water until the intake pipe is full. Secure fittings tightly and turn on your pump. With the swing check valve in place, your pump is fully primed. However, if after running your pump you observe the water level decreasing continuously, this indicates there is either a blockage limiting the flow or a union fitting connection on the intake pipe is not airtight. Check all connections for debris, crimping, or cracking and tighten or replace parts as needed.

No Valve

What to expect for priming cycle **without** a swing check valve installed. In installation applications where no swing check valve is installed, it is important to install a priming pot to facilitate priming. The Cascade series is designed to operate as gravity fed or with a swing check valve and priming pot installed. Without any of these factors in place, the system will not function properly. If working with an installed priming pot, the lid should be removed, priming pot filled with water, lid replaced ensuring all fittings are tight and sealed with PTFE paste or similar sealant. Do Not use PTFE tape. Be sure all water supply valves are open, then connect the power supply to start the pump. It is important to note that the resulting water flow may initially be very little for the first few minutes. If at anytime, no water is flowing into the priming pot, the pump should be shut off, threaded fittings and unions rechecked, water refilled and system restarted. If the problem persists, contact technical support.

Essentially, the Cascade will not have a prime cycle; however, the needs of the system will vary slightly based on pipe type, diameter, suction lift height, horizontal distance, motor speed and horsepower. A check valve and a priming pot are excellent tools to aid in the ease of operation of a Cascade pump.

For system specific assessments including suction lift and friction loss guidance and operating questions, please call 503-356-5888 or email sales@performancepumps.com.

General

Before Installation

Open the pump box when received and inspect for evidence of rough handling or damage to the pump and verify the product ordered. If damage is found, notify the freight carrier and contact the vendor purchased from immediately. For order discrepancies, contact the vendor purchased from immediately.

If using smaller than 1.5" pipe, excessive fittings such as elbows, sweeps or reducers, using an excessively long pipe run, additional strainers or any other water flow restriction device, can increase the time to reach full flow. Refer to the Pump Operation information on page 3.

Proper installation of your Cascade pump will help ensure years of trouble free service.

1. Position the pump as near to the water and as low as is practical. This will help reduce the time to reach full flow, avoid cavitation, and maximize your pumps performance.
2. Minimize friction loss by using the appropriate diameter pipe determined by gallons per minute flow, reducing run length, and minimizing the number of elbows and fittings as much as possible.
3. Maximize your pumps service life by protecting the motor from the elements by ensuring it is well covered and adequately ventilated. Exposing your pump to excessive heat or moisture will shorten the life of the motor.
4. **WARNING** Protect the motor against dirt, water, and all foreign matter. If the motor has been flooded, do not operate it until it has been checked by an authorized motor technician and has been found to be safe to operate. If the motor is damaged by dirt, moisture, foreign matter or corrosion it is not covered by the warranty.
5. Mount the motor to a stable base where it will not get submerged. Use caution when installing in a vault. Be sure proper drainage is in place to prevent flooding. A sturdy pedestal under the pump is beneficial in a vault application to maximize height above the ground. Ensure the vault is properly ventilated.
6. The Cascade series pump ports are 1.5" NPT on both the inlet and discharge ports. The 1.5" NPT ports may be connected with fittings available from PerformancePro Pumps (MPF-215) or standard 1.5" NPT PVC fittings available at your local hardware store and should be connected to PVC or flex pipe plumbing. All plumbing lines should be well supported and properly aligned. This will prevent undue stress to the housing and fittings. Use a good primer and PVC cement to glue pipe connections.
7. Installations in which the water level is elevated above the pump it is highly recommended to use a ball or swing type check valve to prevent back flow and possible reverse rotation. A ball valve will supplement a swing check valve and allow flow adjustments.
8. **FILL THE PUMP HOUSING AND ENTIRE SUCTION LINE WITH WATER BEFORE STARTING THE PUMP.**
9. When determining pump placement, it is important to consider the distance and height from the water source. To reach full flow without an inline swing type check valve, the pump should be positioned at or below the water source level unless a priming pot is installed. Positioning is also important to maintain the pumps ability to maintain prime and minimize cavitation.
Do not use spring loaded check valves!

Installation

It is recommended to hire a licensed electrician or experienced serviceperson to install your pump.

1. After thorough inspection, carefully remove the pump from the box.
2. Secure the pump on a solid, flat foundation. A covered location is always best and care should be taken to ensure adequate ventilation. See installation tips for beneficial tips.
3. Install a ball or swing type check valve as needed to facilitate pump disconnection, flow control and servicing.
4. Connect plumbing to the pump by dry fit testing first to ensure proper fit and proper pipe alignment. Be sure all parts are in place before gluing.
5. Once proper fit and alignment is established, use proper pipe sealant designed for plastic PVC pipe. Support plumbing as needed to prevent strain and damage. Do not over tighten fittings.
6. Wiring of this pump should be in accordance with the wiring diagram located on the motor. Ensure the pump is wired for the correct supply voltage and is supplied by no smaller than 16 gauge wire. The circuit breaker should be 20 amp but no less than 15 amp. It is recommended that wiring be performed by a licenced electrician. For 3 phase wiring, see section 7 under Electrical.
7. If your pump will be hardwired, be sure to ground the motor correctly by connecting code compliant wiring to the green grounding screw located under the wiring plate.
8. When wiring is complete, double check intake and discharge fittings to ensure a snug fit. Note: There may be installations in which plumbing allows for trapped air in the system. If this happens, priming will be difficult. In this case, loosen the discharge fitting slightly to allow trapped air to bleed off. Once primed, tighten the discharge fitting.
9. On flooded suction systems where the water source is higher than the pump, the pump will fill with water once the supply valve is opened. However, on both flooded and non-flooded systems it is recommended to fill the pump housing and suction line with water.
10. Fill the pump housing and supply lines with water. Turn the motor on by plugging in the unit or switching on the power supply. Priming should be immediate as Cascade series pumps should be primed at initial start up. However, with a priming pot attached full prime time may vary in length. See page 3 for details. Water should continue to flow into the housing as the pump completes the priming process. The priming process should not take longer than three (3) minutes with continual inflow of water. The pump should never run dry. If at any time water stops flowing into the pump housing, shut the pump off immediately and see Troubleshooting Tips or Pump Operation pages for more information.

Note:

At initial start up, the water level in the pump housing, should drop rapidly and have a small amount of water entering the pump immediately. If no air leaks or obstructions are present the small amount of water flow will continue to gradually increase resulting in full flow operating at maximum performance.

Electrical

Before wiring any part of the motor be sure the power is disconnected.



It is recommended that wiring be performed by a licensed electrician or professional service person. If pump has a factory preinstalled cord, wiring has already been set and this step is not needed; unless voltage change is required in which case the cord will need to be removed and steps followed below.

1. Inspect the motors internal wiring to ensure voltage supply is matched between the motor and the power source. If voltage does not match, it will damage the motor and void the warranty.
Example: If connecting your pump to a 115V circuit, make sure the motor connections match the 115V wiring diagram listed on your particular motor.
2. Supply voltage must be within +/- 10% of nameplate voltage indicated on the motor. Incorrect voltage supply may result in fire or damaged motor and voids the warranty. If you are not certain, please consult with a licensed electrician.
3. Use designated supply wire size specified in the chart below. Correct wire size is necessary to avoid electrical insufficiencies, allowing the motor to run cooler, more efficiently and eliminating line voltage loss. It is important to connect your pump to a ground fault circuit interrupter (GFCI) for safety.
4. Wire motor following the connection diagram located on the motor. Note differences in high and low voltage arrangements. If a cord has been preinstalled the connection was completed at the factory.
5. Be sure all connections are clean and tight. Ensure the motor is properly grounded. Typically a green ground terminal is located inside the motor connection box. The ground wire must be properly connected to an electrical service ground to safely operate.
6. The pump must be connected to an adequately sized circuit. It is recommended to have a dedicated circuit that will prevent voltage drop from other loads as occurs on shared circuits.
7. When using 3 phase power the motor leads must be energized in the correct sequence to provide the correct motor rotation. When viewed from the back end (opposite drive end), the motor must rotate clockwise. Incorrect rotation could destroy the pump and void the warranty. If sequence of the incoming electrical supply lines is not known, briefly connect the power for a second or two to determine the rotation while looking at the fan through the motor end plate on the back end (opposite drive end) of the motor. If you are unable to see the fan you will need to remove the drip cover (solid plate) on the back end of the motor (opposite drive end) in order to see the motor shaft as this unit type will not have a visible fan. If the rotation is incorrect, exchange any two of the connected leads and retest.

- * Risk of shock! Connect only to a ground fault circuit interrupter (GFCI). Contact an electrician if uncertain.
- * Do not bury electrical cord unless installed in certified conduit. Locate the cord safely to minimize accidental damage.
- * Replace damaged cords immediately to minimize risk of electric shock.
- * Do not use extension cords to supply electricity to the pump.

RECOMMENDED WIRING AND CIRCUIT BREAKER DATA

CIRCUIT DATA			WIRING DATA					
HP	CIRCUIT	VOLTS/Hz/PH	WIRE GAUGE	WIRING SIZE PER AMPERAGE CAPACITY				
				25-50 ft	100 ft	150ft	200ft	250ft
1/3 - 1/2	15 Amp	115 or 230/60/1	16	13 amps	10 amps	*	*	*
3/4	20 Amp	115 or 230/60/1	14	15 amps	13 amps	7 amps	*	*
1	20 Amp	115 or 230/60/1	12	20 amps	15 amps	10 amps	8 amps	7 amps
1.5	30 Amp	115 or 230/60/1	10	20 amps	20 amps	15 amps	10 amps	10 amps

*Not recommended for use at this length. Note: The longer the wiring length the lower the amp conductivity due to voltage drop.

ELECTRICAL

Maintenance

Cleaning the basket:

For Cascade systems with an attached strainer pot.

The strainer basket in the priming pot should be inspected and cleaned at least one (1) time per week, more often if excessive debris is present in the operating environment.

1. Turn off your pump and disconnect from the electrical source by unplugging or turning off the breaker.
2. If you have a ball valve placed at the return side of your pump, be sure to close the valve to prevent backflow.
3. Remove the lid by holding the tabs and turning counter clockwise. Take care if the lid is too tight. Slightly bumping the tabs may aid in releasing the grip. Remove the lid and clean out the basket. It is recommended to clean out the basket using a sprayer on a garden hose and a brush as needed. Do not hit the basket on any hard surface as this will weaken and damage the basket.
4. Reinstall the basket.
5. Fill priming pot (basket section) with water.
6. Replace the lid securely.
7. Open ball valve (if present).
8. Connect power and start the pump.



If your pump has low incoming water flow at start up, ensure water continues to flow into the pump. Full flow should be obtained within three (3) minutes with continual water flow into the pump. If at anytime water stops flowing, turn the pump off immediately. Refer to page 3 for further details. If the pump runs dry, the volute (main pump housing) may be hot, allow the pump a minimum of one hour to cool before opening the pipe or pump. The volute housing or strainer pot (if attached) should be cool to the touch before opening. Danger of burn if opened when hot.

Seals and Bearings:

Pump seals and bearings experience normal wear and degrade over time. It is recommended to change pump seals every three (3) to four (4) years for fresh water applications and every year for salt water applications. The frequency of replacement will be determinate upon environment and water quality. If leakage is noticed at anytime, check troubleshooting tips and contact us for parts and advice. If the pump becomes abnormally noisy, this could be a sign that the bearings are failing and need replacement. There are a few options for repair when an issue occurs.

1. Contact PerformancePro Pumps to obtain a return authorization and ship the pump to us for repair.
2. Contact PerformancePro Pumps for a list of authorized motor repair centers near you. Note that this option may not honor any warranty but may provide a good alternative.
3. If you are mechanically minded, the option to order bearings and a seal kit from PerformancePro Pumps or your local dealer is available for you to perform the repair.

For questions or support contact:

Parts and Service Dept. Ph: (503) 356-5888 E: techhelp@performancepropumps.com

Pump Disassembly

- Tools required:
1. (2) 7/16" wrenches (for 2-3/4" bolts)
 2. Large flat blade screwdriver
 3. Small flat blade screwdriver
 4. 9/16" open end wrench (for 1" bolts)

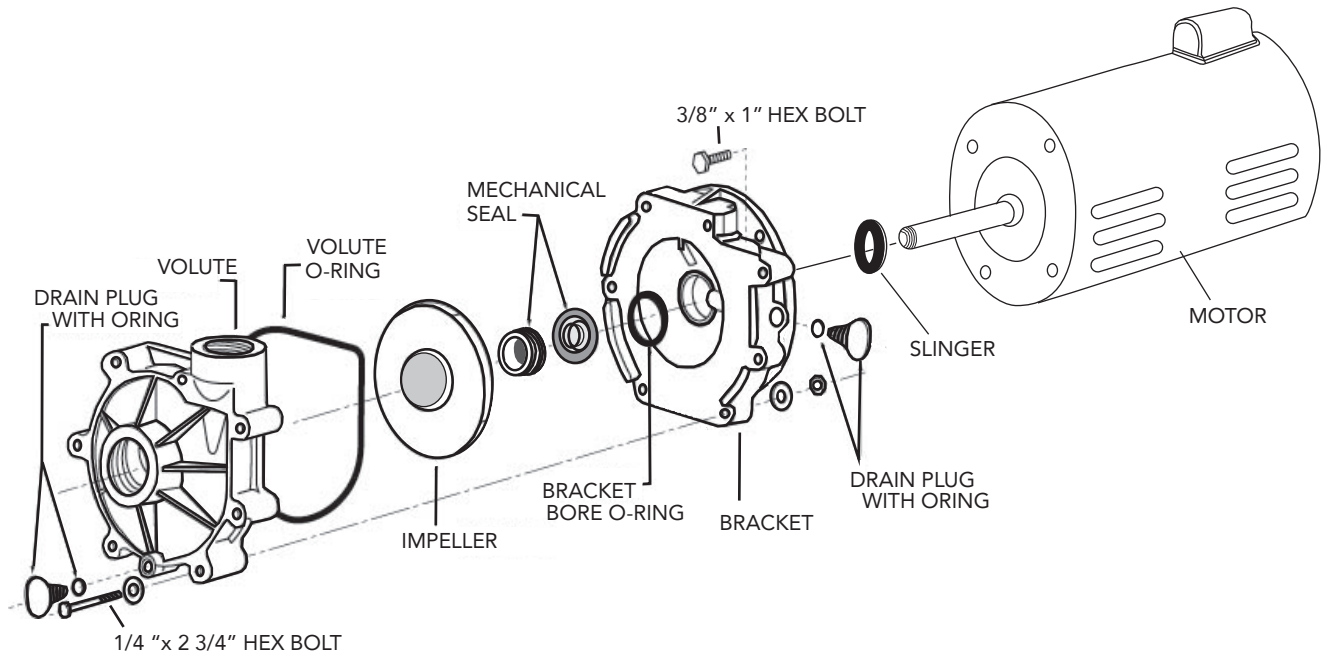

Disassembly for repair can be made as follows:

1. Disconnect the pump from the power source by unplugging or turn off at the circuit breaker.
2. Close all necessary valves on inlet and discharge lines and drain the pump by removing both drain plugs.
3. Loosen and remove the seven (7) 2-3/4" hex bolts that hold the volute and the bracket together.
4. Pull the rear sub-assembly away from the volute. The volute may remain attached to the plumbing.
5. Hold the motor shaft stationary by removing the cover on the opposite end of the motor. Insert a screwdriver in the slot or a wrench on the opposite drive end of the motor shaft depending on the motor design and unscrew the impeller by turning it counter clockwise as viewed from the pump end.
6. To remove the shaft seal, place the bracket face down on a flat surface and press out the mechanical seal from the back side. Never pry it out from the front. Carefully remove the ceramic seal from the back of the impeller hub by carefully prying up with a small flathead screwdriver.
7. Loosen and remove the four (4) 1" hex-bolts that hold the bracket to the motor face. Slide the bracket away from the motor.
8. Clean the bracket, seal housing and the motor shaft as necessary. Remove slinger if replacing bearings. If the motor shaft has corrosion build up, use emery cloth to clean it.

Parts Replacement and Pump Assembly

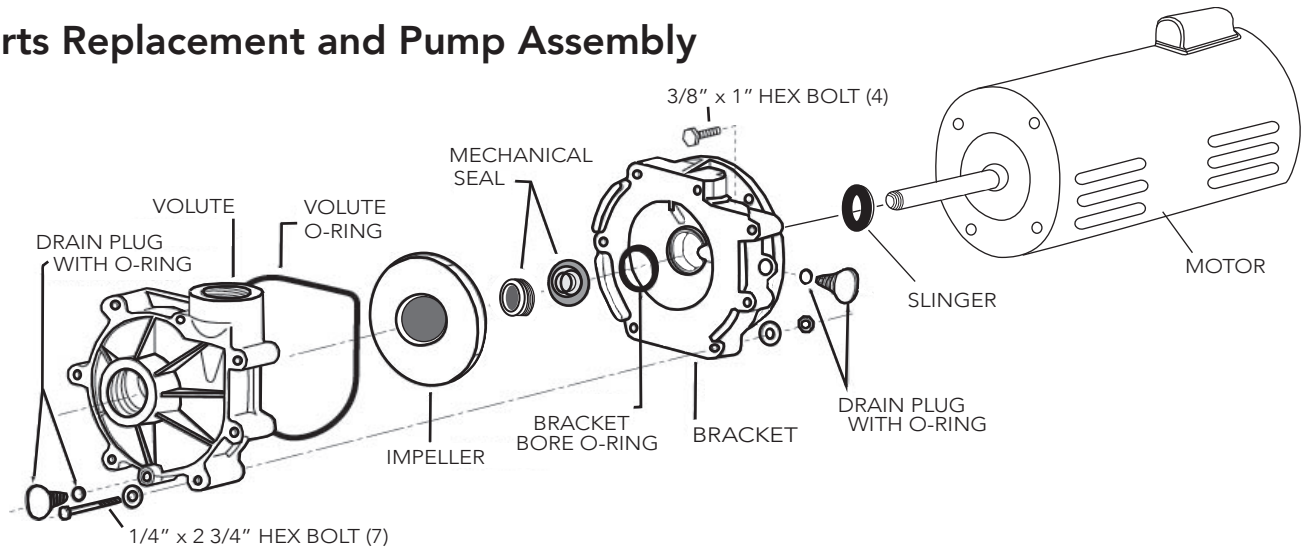

Tools required: (2) 7/16" wrenches, small & large flat blade screwdriver, 9/16" open end wrench (for 1" bolts)

1. To install a new shaft seal: Clean or replace the bracket bore o-ring. Moisten bracket bore o-ring with water prior to installing to prevent rolling.
2. Press the seal into the bore without touching or putting pressure on the delicate carbon face by pushing on the stainless steel collar. (A large socket or pipe nipple may be used to facilitate installation.) **AVOID TOUCHING THE CARBON SEAL FACE TO PREVENT DAMAGE.**
3. Clean as necessary the impeller hub and press in the ceramic/rubber part of the mechanical seal (see tip). Make sure it is sitting flat. The polished white ceramic face must be face out, not the rubber boot!
Tip: Moistening the rubber boot with water prior to installation aids in proper seating.
4. Install the slinger rubber washer on the motor shaft. Install the bracket to the motor. Install and tighten the four (4) 1" hex bolts evenly.
5. Screw the impeller clockwise onto the motor shaft while holding the motor shaft stationary until it makes firm contact.
6. Make sure the volute o-ring is clean and install the large o-ring in the volute groove.
Tip: Installing the volute o-ring with the volute intake port side down will ease installation of the bracket o-ring.
7. Assemble the motor sub-assembly to the volute using the seven (7) 2-3/4" hex bolts. Do not tighten until all seven (7) hex bolts are in place and hand tightened, then tighten all seven (7) bolts uniformly in an alternating opposing sides pattern. Do not overtighten.
8. Insert both drain plugs with o-rings installed and tighten. If present, install strainer pot and fill the volute/strainer pot with water.
9. Open all valves on the system and reconnect the power to start. With an attached strainer pot, wait for the pump to prime while monitoring the water level in the volute/basket area to ensure water is always present. If the pump has been running with low incoming water flow for more than three (3) minutes, shut the system off immediately and check fittings for air leaks. Full flow with installed check valve should be obtained at initial start up. Call PerformancePro Pumps for additional technical assistance.

WARNING

- * Handle the mechanical seal with care to protect the polished and lapped faces of the seal from damage.
- * **DO NOT RUN THE PUMP DRY.** Pump must be filled with water and sealed before it is turned on.

Winterization

Winterizing your pump is necessary if freezing temperatures occur in your geographic area for extended periods of time. If freezing temperatures are not common but may on occasion drop below freezing, it is advised to follow winterization procedure to protect your pump.



Freezing temperatures cause water to expand and may result in damage to the pump, plumbing, and other connected components resulting in costly repairs.

Full disconnection method:

This method is best for pumps situated outside without protection of a building or vault.

1. Disconnect the pump from the power source by unplugging or turning off at the circuit breaker.
Note: If hardwired, you may either disconnect the electrical connection (a qualified electrician should perform this) or you leave the motor connected and disconnect the pump end. If you choose this option, please follow pump disassembly instructions and insulate and cover the motor for protection.
2. Close all necessary valves on inlet and discharges lines and drain the pump by removing both drain plugs. If strainer pot is installed, the lid may be loosened to facilitate better drainage. Tip: Store drain plugs and union or fitting o-rings in a resealable bag and tape the bag to the pump to prevent loss.
3. Once drained, loosen the intake and discharge port connections.
4. The pump can now be removed. Be sure the pump is fully drained and if strainer pot is installed remove the lid before being stored. The lid may stay secured if prior to storage the lid is removed and fully dried. Store with drain plugs removed. Your pump is now ready for storage in a dry, warm location such as a garage.
**Be sure to drain the water from the plumbing on your system and related components to prevent damage.

Connected method:

This method is best for pumps situated in a vault, shed or other covered outdoor location that may be difficult to fully remove.

1. Follow steps 1, 2 and 3 above.
2. Once drained, if strainer pot is installed, remove and dry the lid and place over the top without latching.
3. Drain all plumbing lines on your system.
4. Insulate the pump and exposed pipes, fully covering to prevent moisture intrusion and freezing temperature exposure. Do not directly cover with plastic sheeting as this can create condensation that can result in damage.

Troubleshooting

The following troubleshooting tips support the most common issues. For additional assistance, please contact techhelp@performancepumps.com or 503-356-5888.

PROBLEM	KNOWN ISSUE	TRY THIS
Pump is not priming	No water in strainer pot if installed	Fill strainer pot with water and close lid. Ensure plumbing valves are open.
	Low water in the strainer pot if installed	Check basket to make sure seated correctly and reinstall lid. Check lid for cracks and lid oring for flat spots or cracking. Check intake and discharge union fittings for cracks or loose connection. Replace or tighten. Connections must be airtight.
Motor is not turning	Circuit breaker has tripped or has no power	Reset circuit breaker and/or GFCI.
		Check electric supply to verify power supply is present. Test a secondary location if needed.
		Capacitor failure. This may be tested. Call for details. Bearing seized. Rotate motor shaft by hand to test. If shaft does not freely spin, replace bearings.
Low flow	Water flow has slowed or is intermittent	Clean filter basket of debris if strainer pot installed.
		Check for impeller clog. See disassembly instructions or call for details.
		Check for leaks in volute housing, lid* and union connections. (* only if strainer pot installed)
		Check for obstructions in plumbing and clear if found.
Motor overheating	Seems overly hot and is shutting down or shutting off and on intermittently	Possible incorrect wiring. Have an electrician test.
		Test breaker. Replace if needed.
		Increase air flow if restricted.
		If pump is located in direct sunlight, try providing a properly vented shade covering.
Pump is leaking	Water leaking between motor and pump housing	Replace mechanical seal and bracket o-ring. Inspect bolts in volute housing by checking for loose fit of the 7) 2-3/4" bolts. Tighten or replace.
	Water leaking at lid* or fitting	Check lid or fittings for cracks. Replace if needed.
	(* only if strainer pot installed)	Check lid or fitting sealant for cracking or gaps. Replace if needed.

Parts

PARTS

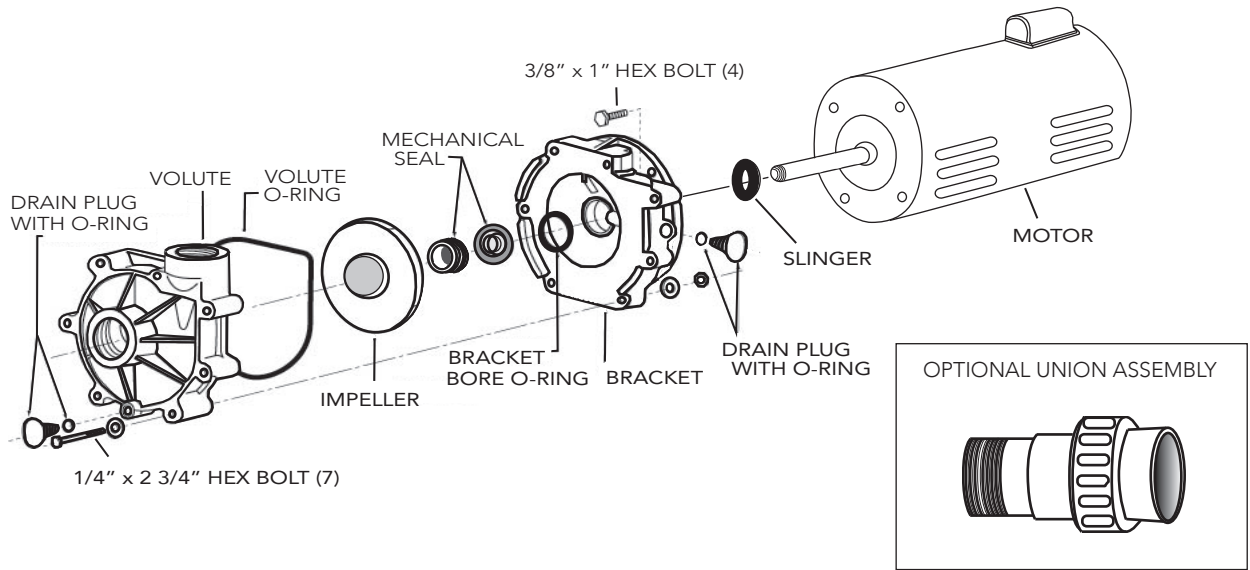

ITEM	PART NUMBER	C1/3	C1/2	C3/4	C1	C1 1/2	C2
BEARINGS	BEARING-03	X	X	X	X	X	X
BRACKET	PPB-10	X	X	X	X	X	X
BRACKET BORE O-RING	PBO-10	X	X	X	X	X	X
DRAIN PLUG	PPD-10	X	X	X	X	X	X
HARDWARE	MPH-20	X	X	X	X	X	
IMPELLER	CN1/3	X 4.80"					X
	CN1/2		X 4.80"				
	CN3/4			X 4.80"			
	CN1				X 4.80"		
	CN1 1/2					X 4.80"	
	CN2						X 4.80"
	CN3						
MOTOR BASE	MPB-P48		X	X			
	MPB-P56	X			X	X	X
SEAL - STANDARD SALT	MPS-513	X	X	X	X	X	X
	MPS-517	X	X	X	X	X	X
SEAL KIT - STANDARD SALT	C-SK1	X	X	X	X	X	X
	C-SK1-S	X	X	X	X	X	X
UNION ASSEMBLY	MPF-215	X	X	X	X	X	X
VOLUTE	PPV-15	X	X	X	X	X	X
VOLUTE O-RING	PVO-10	X	X	X	X	X	X

Performance Data



PerformancePro PUMPS

Pump Models: Cascade High RPM Series
 Impeller: Various
 Horsepower: 1/3 - 2 RPM: 3450 V: 115/230
 ENC: ODP M: B Hz: 60
 Date: 9-17-20 #732, 734, 736, 738, 740, 742

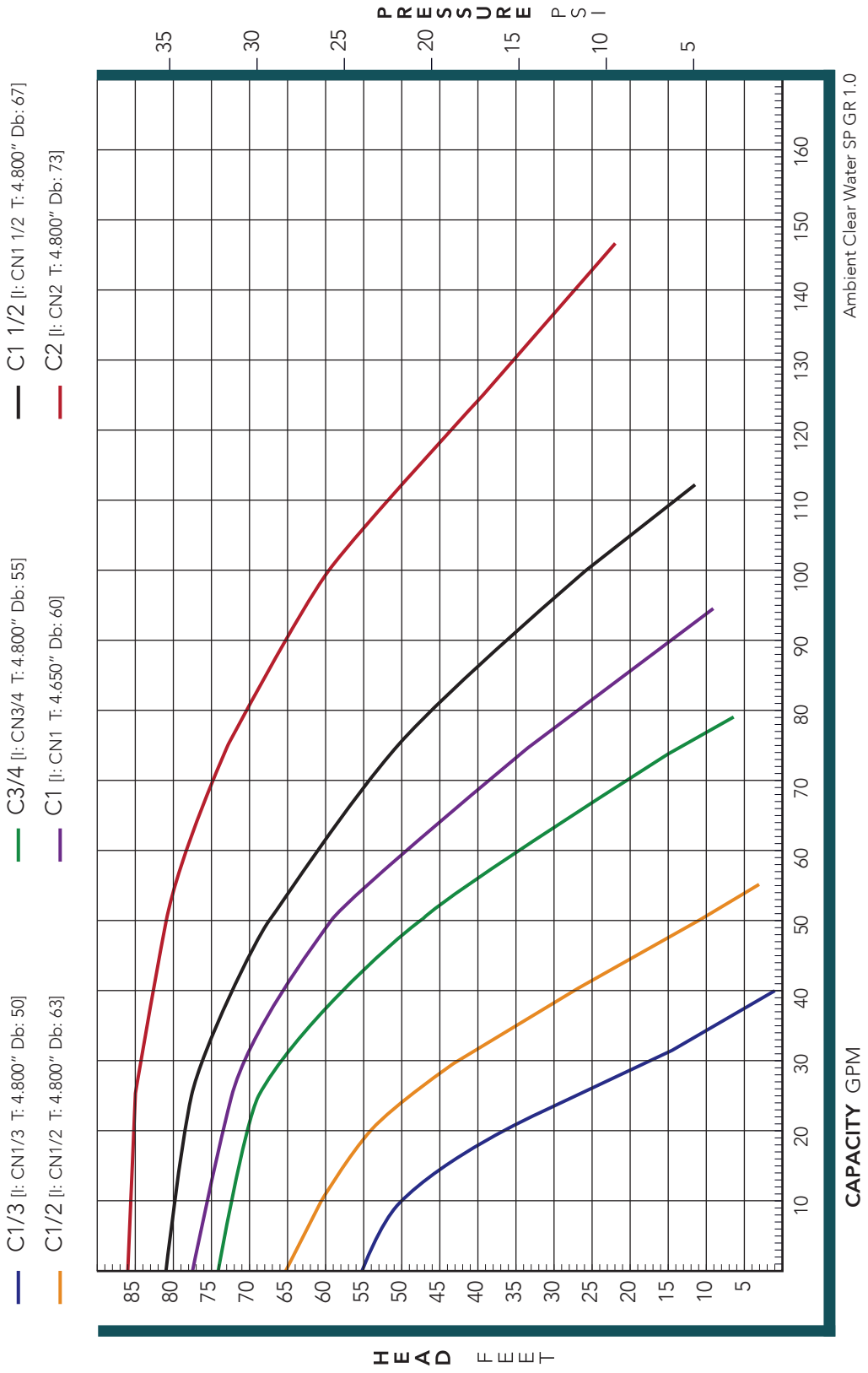

PERFORMANCE

Warranty

PerformancePro Pumps Cascade Series Limited Warranty

This Cascade series product is warranted to the Purchaser (defined herein as the original end user) to be free of defects in construction and workmanship at the time of purchase. In the event this product malfunctions within three years (for fresh water use) or one year (for use with salt water or other suitable fluids) from the date of purchase the sole obligation of PerformancePro Pumps will be to replace or make this product capable of being operated according to the original product description without charges for labor or parts to the Purchaser, and are subject to the following conditions:

1. The malfunction is proved attributable to a defect in construction or workmanship, including repairs performed under this warranty. Malfunction for any other reason - including but not limited to misuse, abuse, negligence, accident, corrosion or salt build up, incorrect wiring or electrical supply, tampering with parts, or improper installation - will not be remedied under this warranty. Problems or damage from failure to comply with instructions in the owner's manual, improper plumbing and positioning, flooding, incompatibility with fluid chemistry and running the unit dry are not covered under this warranty.
2. PerformancePro Pumps must perform all warranty repairs. Purchaser must retain the purchase receipt and present it with this certificate as proof of ownership and entitlement to warranty repairs. The cost of unauthorized repairs will not be reimbursed to Purchaser by PerformancePro Pumps, and are not the responsibility of PerformancePro Pumps. If repairs by Purchaser or a third party damage the product, such damage is not remediable under this warranty.
3. Purchaser shall bear all shipping, packing, and insurance costs and all other costs, excluding labor and parts necessary to effectuate repairs under this warranty. Purchaser will pay for return freight.
4. For applications that involve fluids other than water, the Purchaser shall retain and present to PerformancePro Pumps evidence of purchaser's compatibility tests under actual operating conditions. Any problems caused by a chemical incompatibility of the fluid with the pump materials, are expressly not covered by this warranty.
5. Periodic check-ups and/or maintenance are not covered by this warranty.

6. For all sales in the State of Oregon this is the sole and exclusive manufacturer's warranty. There are no warranties which extend beyond the warranty set forth herein, and in accord with Oregon Revised Statutes ORS 72.3160 any and all implied warranties, including any warranties of merchantability and fitness for particular purpose, are disclaimed and excluded. Some States do not allow disclaimers/exclusions of, or limitations on how long an implied warranty lasts, so in such States, and except as is otherwise provided by applicable law of said States, no action on a warranty implied at law shall be commenced more than one year following the date of purchase. No action shall be brought for breach of any express warranty subsequent to the expiration of the express written warranty.

7. Incidental and consequential damages (specifically including, but not limited to, damages for loss of profits or damages relating to down time of personnel, equipment, or facilities) caused by malfunction, defect, or otherwise, whether alleged to be the result of breach of any express or implied warranty, or the negligence, willful misconduct or other act of PerformancePro Pumps are not the responsibility of PerformancePro Pumps, and to the extent permitted by law, are hereby excluded, including, but not limited to property damage, and to the extent not prohibited by applicable law, personal injury or death and Purchaser hereby agrees to expressly waive any claim for all such damages. If a final determination is made in a court of competent jurisdiction that any one or more of the damages which are disclaimed, excluded and/or waived under this paragraph are not allowed under public policy or applicable law, then the disclaimer, exclusion and waiver of all of the other damages not prohibited by public policy or applicable law shall continue to apply.

8. This warranty does not apply to any malfunction arising out of any application of this product other than in a use compatible with the manufacturer's product description, unless such application is, upon request, specifically approved in writing by PerformancePro Pumps.
9. The provisions of this warranty are severable and if any provision shall be deemed invalid, the remaining provisions shall remain in full force and effect.
10. This limited warranty extends only to the original Purchaser (end user) and does not extend to transferee or purchaser from the original Purchaser. Any purported assignment without the consent of PerformancePro Pumps shall be null and void.
11. No warranty whatsoever of chemical compatibility or application suitability is given. It is the sole responsibility of the Purchaser to determine if the merchandise purchased is suitable for Purchaser's specific application. PerformancePro Pumps strongly advises that the customer perform any and all tests necessary to determine material compatibility and product suitability for customer's specific conditions and needs.
12. This contract shall be governed by and in accordance with the laws of the State of Oregon. Purchaser agrees that proper jurisdiction and venue for any claim brought hereunder is in Washington County, Oregon.
13. This limited warranty is incorporated by reference into the contract of purchase for the products supplied by PerformancePro Pumps to Purchaser under said contract.

PROTECT YOUR INVESTMENT!

Exposure to the elements can result in corrosion
and reduced service life of your pump.
Protect your pump motor from the elements today!

- Sturdy construction
- Customizable precut knockout sections
- Excellent weather protection
- Noise abatement
- Fits all Cascade series models
- Easy to assemble

PART #:
MPC-10

